

141R A.C Mount

LS1 Camaro, Firebird



Technical Information

This bracket system is designed for Gen III LS1 Camaro and Firebird engines. AS WITH ANY PART OF THIS NATURE, MAKE SURE IT FITS YOUR APPLICATION BEFORE PAINTING OR PLATING. PARTS THAT HAVE BEEN PAINTED, PLATED OR MODIFIED MAY NOT BE RETURNED.

- To insure proper function and installation of this product, please read the following detailed instruction (steps 1-6).

- Unless noted, be sure to start all bolts before tightening.

PARTS INCLUDED IN THIS KIT:

- Front and rear A.C. Bracket plates.
- Idler Bracket Plate.
- 2 $\frac{3}{4}$ " six rib idler pulley
- All necessary hardware and illustrated instructions.
- Heavy duty automatic belt tensioner.
- 99 $\frac{5}{8}$ " Six rib belt (Dayco# 5060990).

PARTS YOU WILL NEED:

- A.C. Compressor (Sanden 508 part# 4514 or comparable).

BRACKET DIMENSIONS:

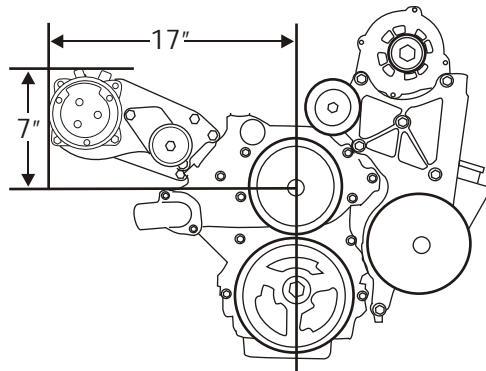

Step 1: Remove Factory Equipment

- Before you begin bracket installation; the removal of the factory six-rib belt and tensioner is necessary.

*NOTE: On early LS motors the passenger side head mounted EGR will need to be removed. GM EGR block-off plate (GM#12558346) will be needed at the intake manifold. Howell Engine Development can assist with ECM modification for early LS applications (810)-765-5100.

Step 2: Bracket Installation

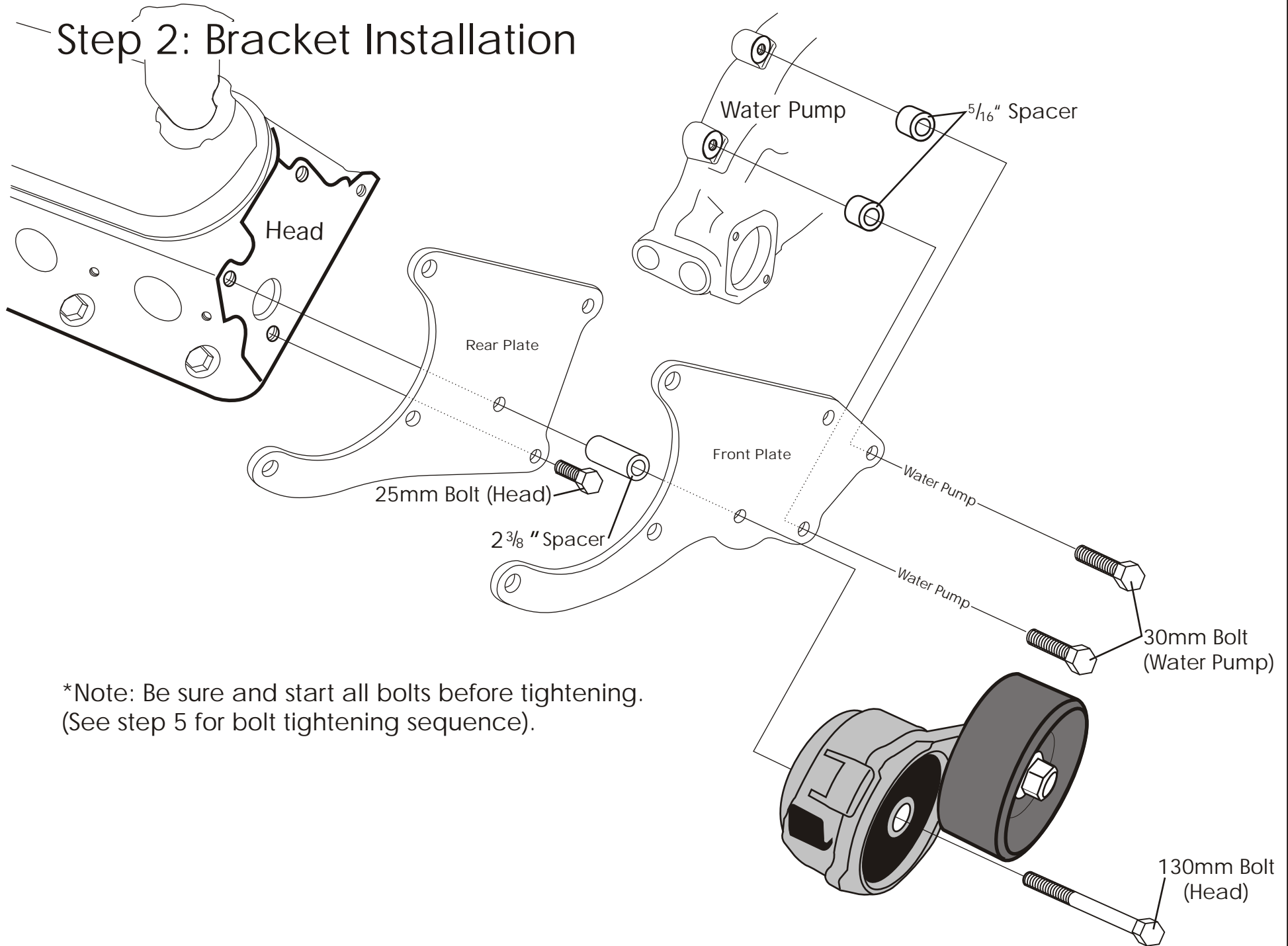

*Note: Be sure and start all bolts before tightening.
(See step 5 for bolt tightening sequence).

Step 3: Compressor Installation

*Note: Be sure and start all bolts before tightening.

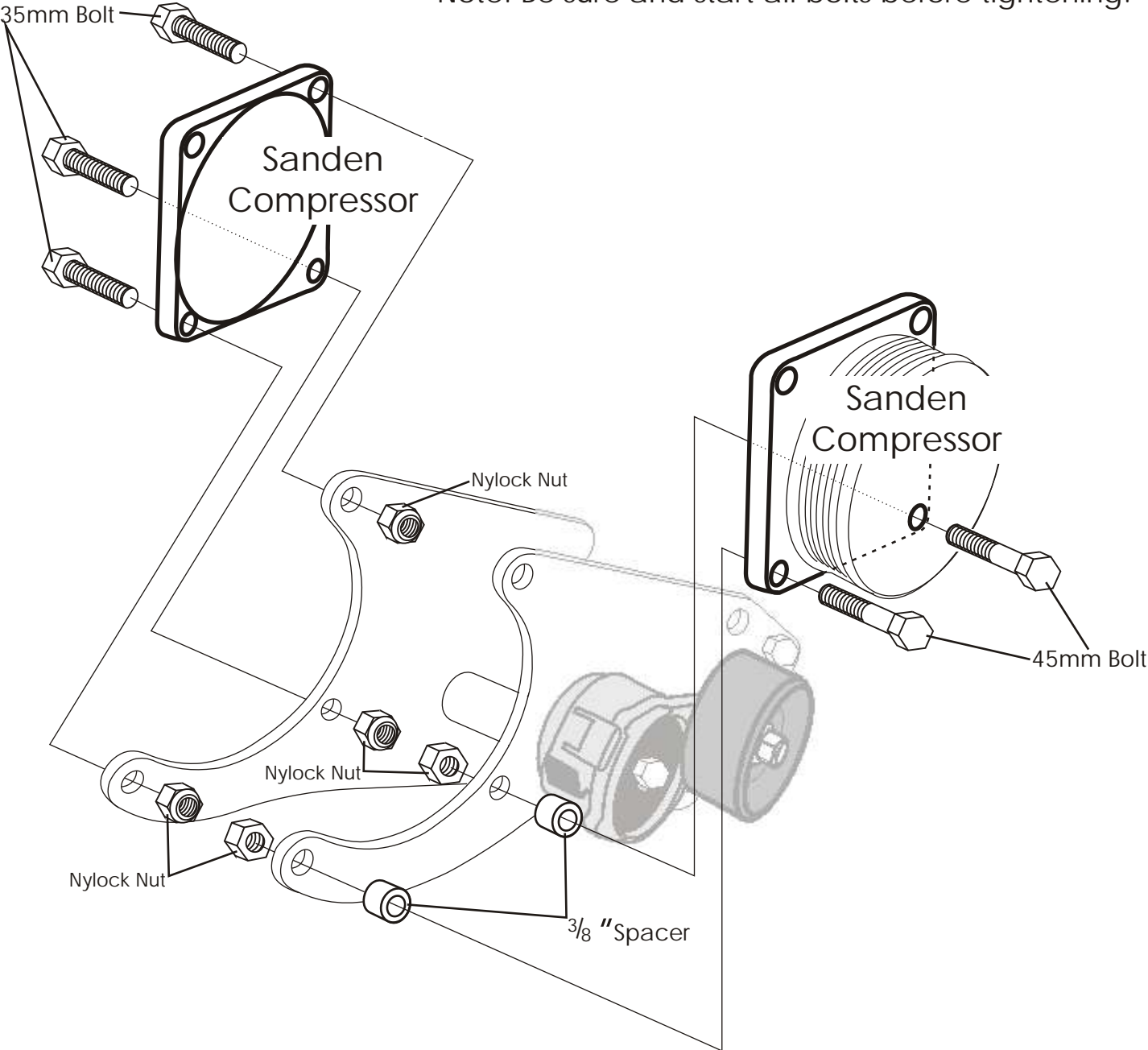

Step 4: Idler Pulley Installation

*Note: Be sure and start all bolts before tightening.
(See step 5 for bolt tightening sequence).

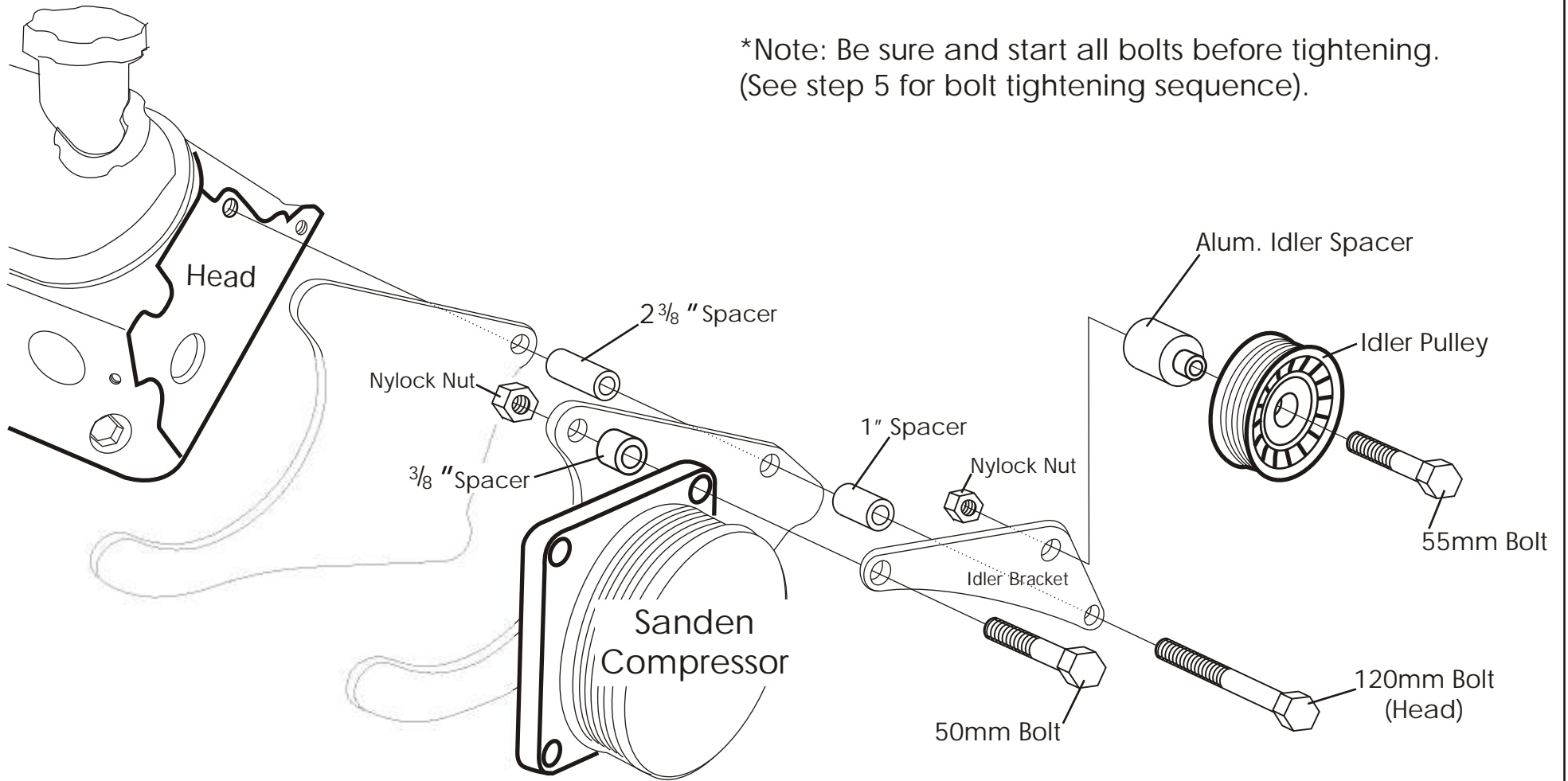

Step 5: Bolt Tightening

When tightening bolts: Lift up on the A.C. Compressor and tighten the 3 bolts that thread into the cylinder head. Next: tighten the 2 bolts at the water pump. Last: tighten all remaining bolts at the A.C. Compressor and Idler Pulley.

Step 6: Install Belt

- NOTE: Sanden A.C. compressors are equipped with a 7 groove clutch pulley; only the inner six grooves will be used in this application (see belt routing below).

Belt Routing

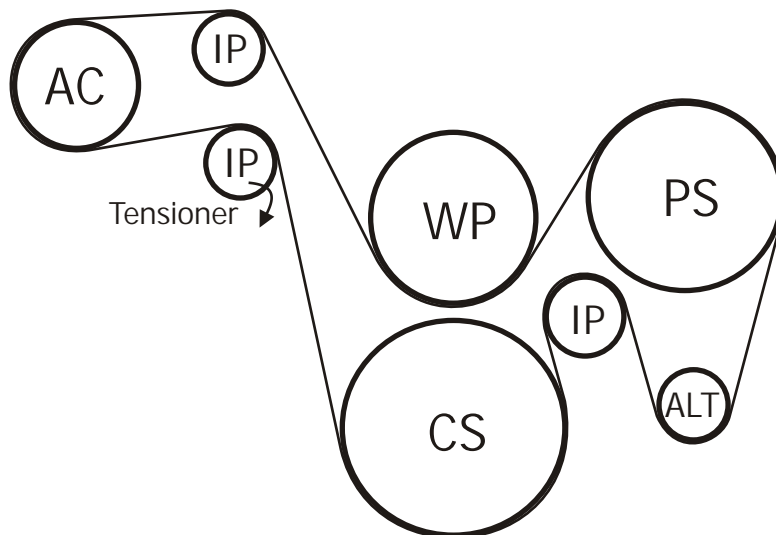

A.C.
Compressor
Mount
141R
LS1 Camaro and Firebird Motor
Passenger Side

ALAN GROVE COMPONENTS, INC.
27070 METCALF ROAD
LOUISBURG, KS 66053

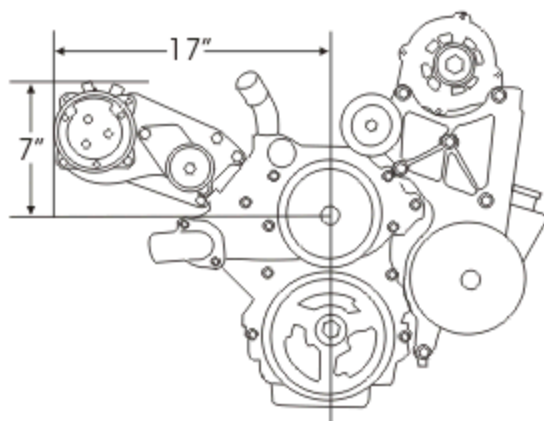

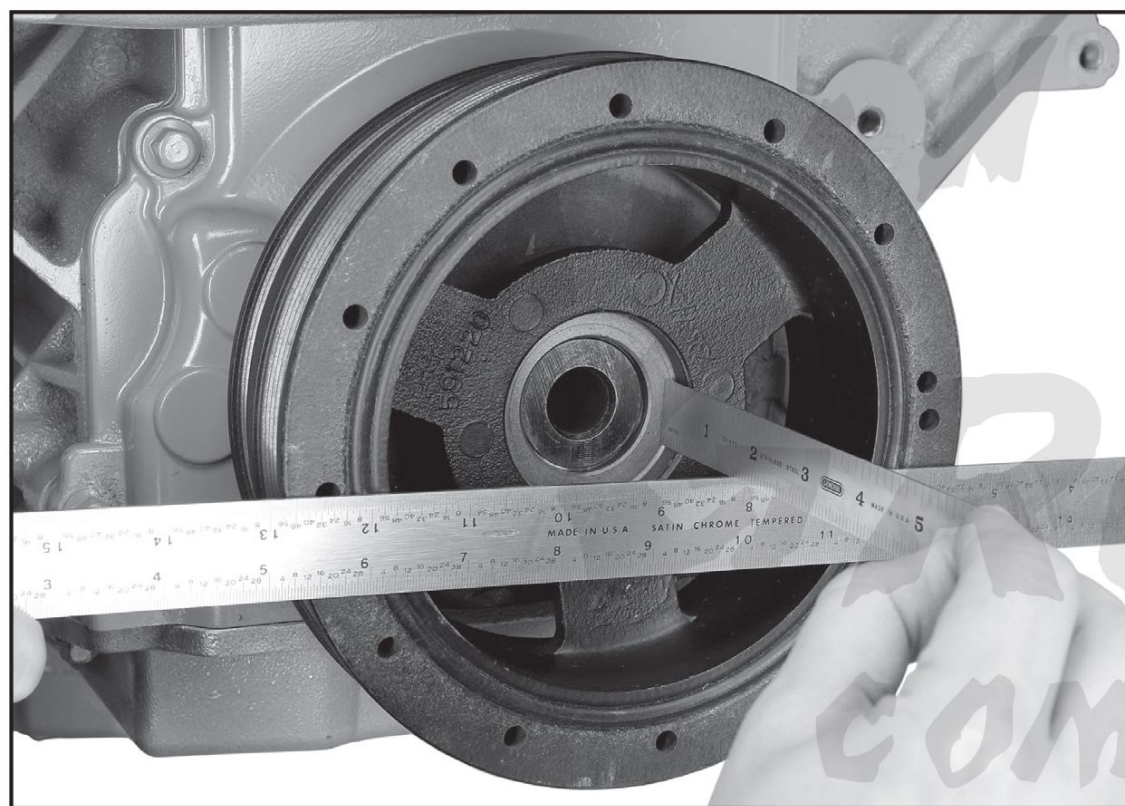

LS BALANCER DIMENSIONS

*With a straight edge placed across the front of the balancer; measure to the machined surface of the balancer.***Note: Balancer retaining bolt does not need to be removed.**

1999 - 2013 Truck

2010 - 2015 Camaro non SS

3" Measurement

1998 - 2002 Camaro/Firebird

2004 - 2006 GTO

2¹/₄" Measurement

1997 - 2013 Corvette

1¹/₂" Measurement